

# Two-Part Clamp Type L2



Repair clamps for the repair of leaks and damages in piping systems, applicable to these types of pipes:

- Steel/Stainless steel
- Casted iron
- Concrete/Cement
- PVC
- GRP
- PE/HDPE

The repair clamps can be used in case of:

- Tears/Cracks
- Holes
- Corrosion/Damages

## Pressure

For water pipes, the following bar ratings are applicable:

Pipe OD	Max Pressure*
90 - 350 mm	16 Bar
351 - 488 mm	10 Bar

## Dimensions

- A** Clamp length: 200/250/300/400/500 mm
- B** Pipe OD (range 20 mm) Ø 90 – Ø 488 mm
- C** Bolt centre distance: 100 mm (distance 50 mm is available on request)

For plastic pipes (PE/PVC) pipes it is advised to use a clamp length of 1,5 x pipe OD

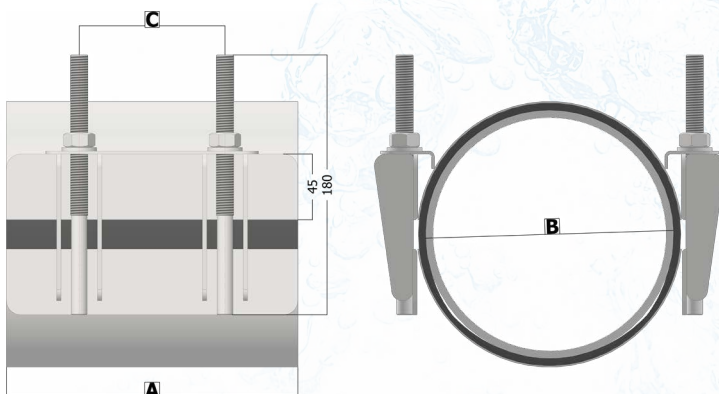

## Material

<b>Stainless steel</b>	AISI 304 (1.4301) / AISI 316 (1.4404)
<b>Treatment</b>	Pickling & Passivating
<b>Bolts</b>	Stainless steel
<b>Nuts</b>	Stainless steel, Electrolytically galvanized

Pipe OD	Bolt	Torque	Bridge plate
90 - 130 mm	M12	80 nm	2 mm
131 - 354 mm	M14	100 nm	2 mm
> 354 mm	M16	120 nm	3 mm

Pipe OD	Sheet thickness
90 - 260 mm	0,8 mm
261 - 478 mm	1,0 mm
478 - 488 mm	1,5 mm

## Gaskets

Rubber gasket with waffle pattern

Gasket	Application	Temperature
EPDM	Drinking water Wastewater Air, Acids.	-20°C to 70°C continuously. Peak to 120°C.
EPDM 150°C	Wastewater, Heated air, Hot water,	-20°C to 120°C continuously. Peak to 150°C
NBR	Gas ,Wastewater, Heated air, Oil	-15°C to 70°C continuously. Peak to 100°C.
Viton	Diversity of aggressive chemicals.	-15°C to 200°C continuously. Peak to 250°C.

In case the product you are looking for is not represented in this document or if you have any other questions, please contact our sales department: [sales@leendersrepairclamps.com](mailto:sales@leendersrepairclamps.com)

\*All bar Ratings are based on factory acceptance test criteria, circumstances which are unique to the situation in which the product is used can influence the maximum pressure. Leenders Repair Clamps BV can therefore never accept responsibility for malfunction caused by external factors.

